

# INSTALLATION / OWNERS MANUALS

## DSD32

### Low Profile Scissor Lift

Capacity 3200 Kg

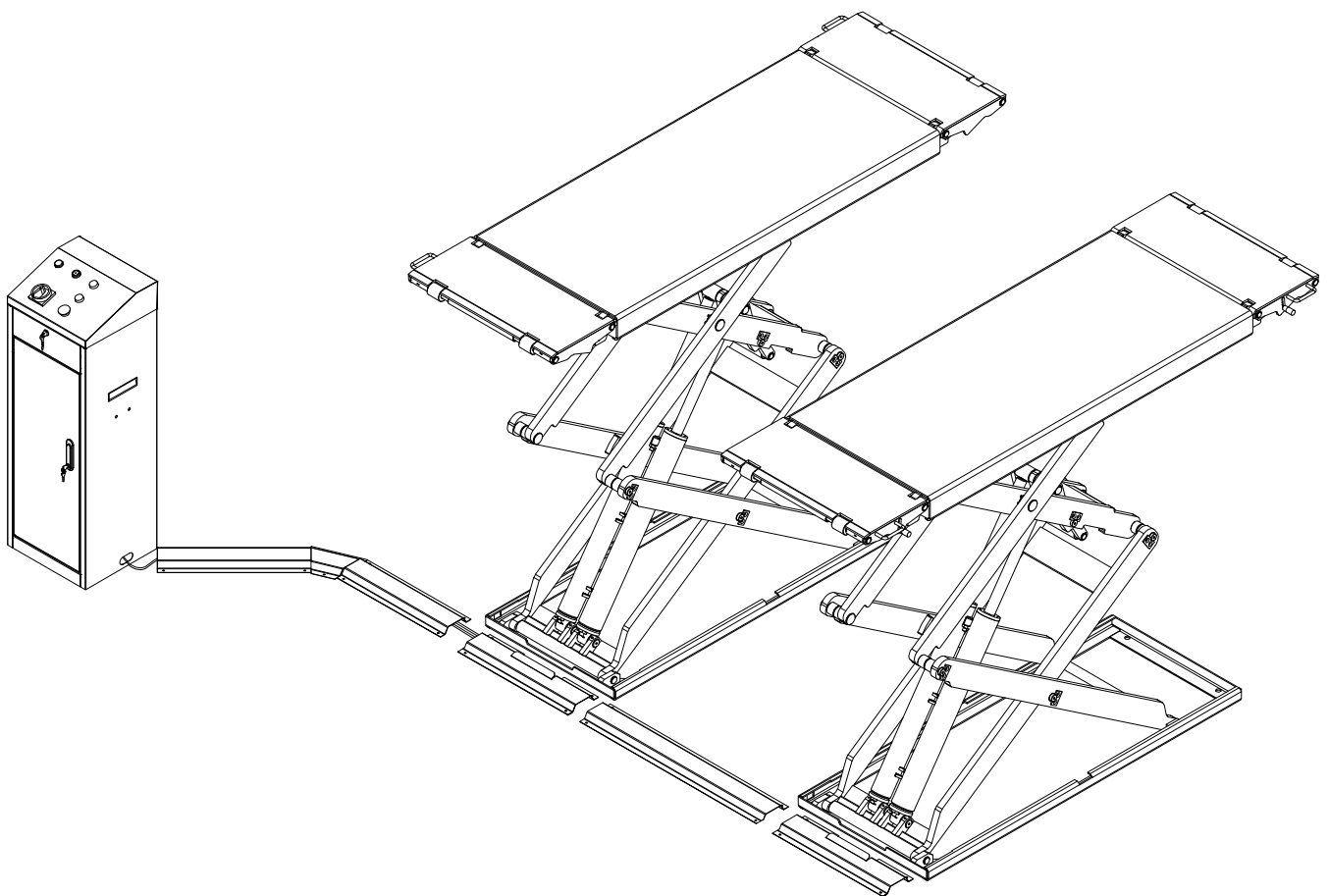

**Read this manual thoroughly** before installing, operating, or maintaining this lift. When done with installation, be sure to return documents to package and give all materials to lift owner/operator. When installation is complete, be sure to run lift up and down a few cycles with and without "typical" vehicle loaded on lift.

## **Special Instructions**

- Any damage caused during packing and transportation shall be claimed by the purchaser to the carrier.
- Safety performance has been taken into account during design and manufacture. However, appropriate training and careful operation can enhance safety. The equipment cannot be operated or repaired without reading this manual.
- The power supply and current requirements marked on the motor shall be checked. Power connection shall be conducted by professional qualified electrician.
- The equipment may not be modified without prior notice. We will not be held responsible for any update of sold products.
- Please carefully read the manual and fill in the Warranty Card and deliver it to the dealer and our company for documentation. Otherwise, it will be deemed as automatic waiver of corresponding service, and user shall bear the consequence themselves.
- The equipment shall not be used to raise any load exceeding rated lifting weight of 3.2 tons.
- Read carefully warning marks on the equipment.

# Contents

<b>I</b>	<b>Basic Specifications and Layout of Low Profile Scissor Lift .....</b>	<b>4</b>
<b>II</b>	<b>Installations and Adjustment of Low Profile Scissor Lift .....</b>	<b>5</b>
<b>III</b>	<b>Operation Instructions of Low Profile Scissor Lift.....</b>	<b>11</b>
<b>IV</b>	<b>Notice for Maintenance and Check of Low Profile Scissor Lift .....</b>	<b>12</b>
<b>V</b>	<b>Troubleshooting of Low Profile Scissor Lift .....</b>	<b>13</b>
<b>VI</b>	<b>Parts Break .....</b>	<b>15</b>

# I Basic Specifications and Layout of Low Profile Scissor Lift

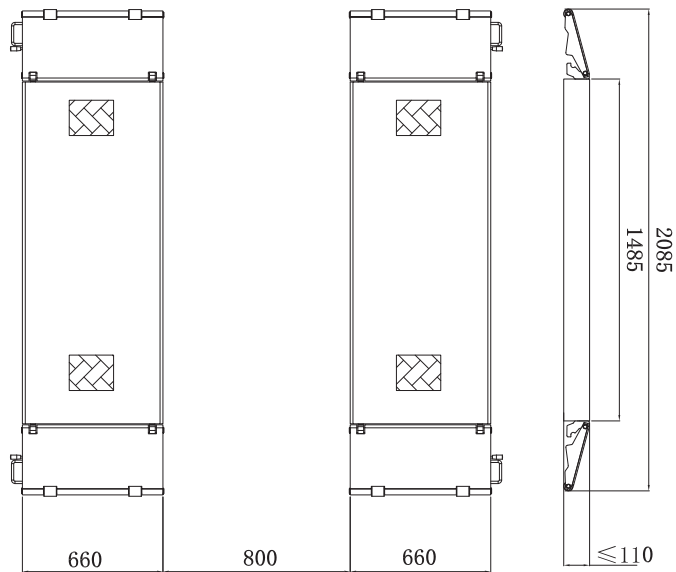
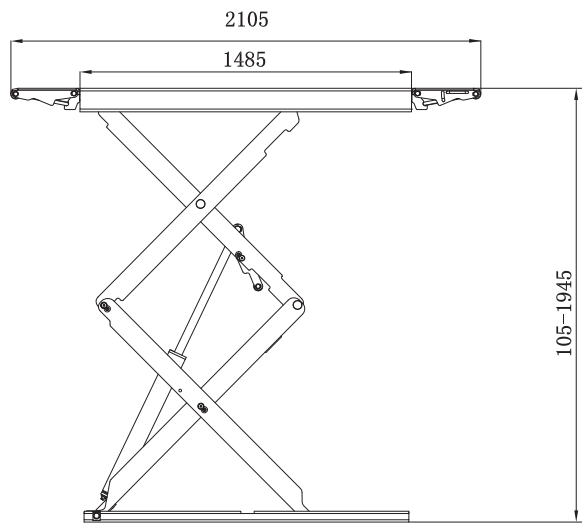

1	Capacity	3200Kg
2	Stroke	1945mm
3	Lowered height	105mm
4	Platform length	1485mm
5	Overall length	2105mm
6	Platform width	660mm
7	Overall width (max)	2120mm
8	Motor performance	2.2kW
9	Electrical connection (3 phase)	380V/50Hz
10	Rising time	$\leq 60S$
11	Lowering time	$\leq 60S$

## II Installations and Adjustment of Low Profile Scissor Lift

### Pre-Installation Preparation

- **Installation Environment**

The equipment should be installed indoors without dust or any other pollution but with full illumination. The control box should be placed in the safe area.

- **Foundation Preparation**

Make the foundation ready for installation in accordance with the foundation drawing. It is critical that the foundation be horizontal, and don't rely too much on horizontal adjustment of the equipment. Thickness and strength of concrete foundation is equally significant, which should be 160mm thick and no less than C20/C25 in strength. It is only after one-week concrete curing that the equipment can be installed. The tolerance of the level of the two pits should be no more than 5mm.

### Transport to the installation location

- The transport can be performed with a forklift or a crane. When transporting with a crane, ensure that the machine does not sway too heavily.



- Open the packages to check whether any part is omitted or damaged in transportation.
- Measure the under frame of the lift and transfer the measurements to the installation site.
- Place the lift on the installation site, with the turning radius gauges in the front direction where the vehicle enters in, and the side of platform with sliding groove on the inside of the lift.
- Place the control box in a location ensuring the operator has a clear view of the load and the lift, and ensure that the operator has avenues of escape if a danger arises.

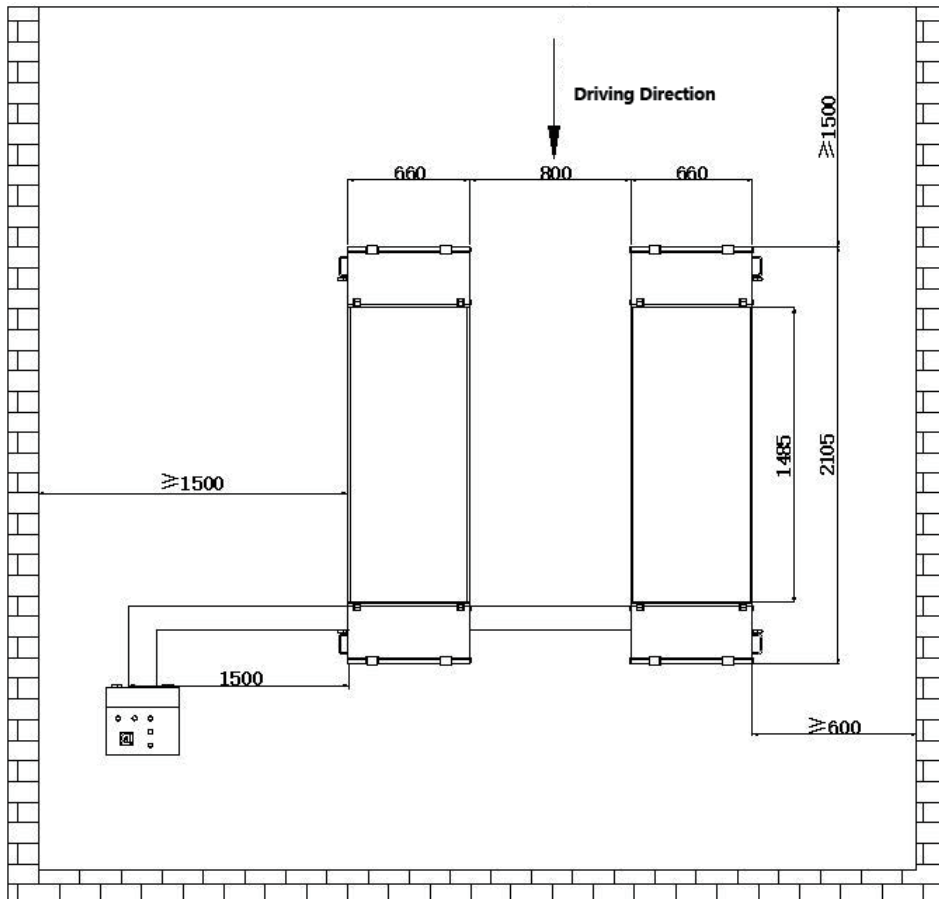

- Note: 1. Foundation concrete is C20  
 2. The level tolerance of two pits  $\leq 5\text{mm}$   
 3. Position control unit left or right

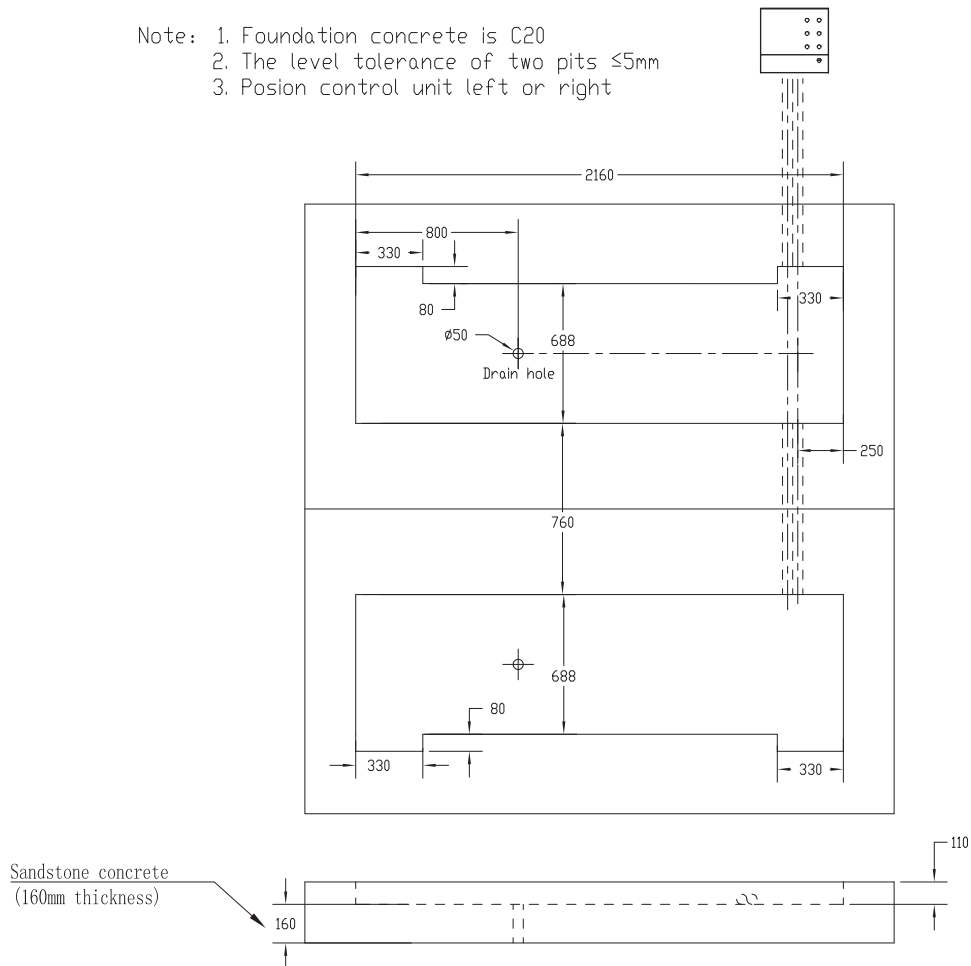

Foundation Diagram

## Hydraulic circuit installation

- Raise the lift to a certain height (where it is appropriate for installers to work in the pits) with a crane or other proper tools, ensure the safe locking latches are in-line, and secure it with the wood blocks or other tools.



- Connect the remaining hydraulic hoses and fittings (during the connection, please protect the hoses and fittings, preventing foreign material such as dirt from entering the hydraulic circuit) according to Hydraulic Circuit Installation Diagram and Hydraulic Schematic.
- Fill 20L HM32 or HM46 ant wear hydraulic oil into the oil tank (the users provides the hydraulic oil), with the oil level 10mm lower than the top of the oil tank at the least and 30mm at the most (which can be checked with the stock rod on the air shield on the filling mouth of the oil tank). If the oil is insufficient during the process of debugging or use, please fill in some according to the actual situation.

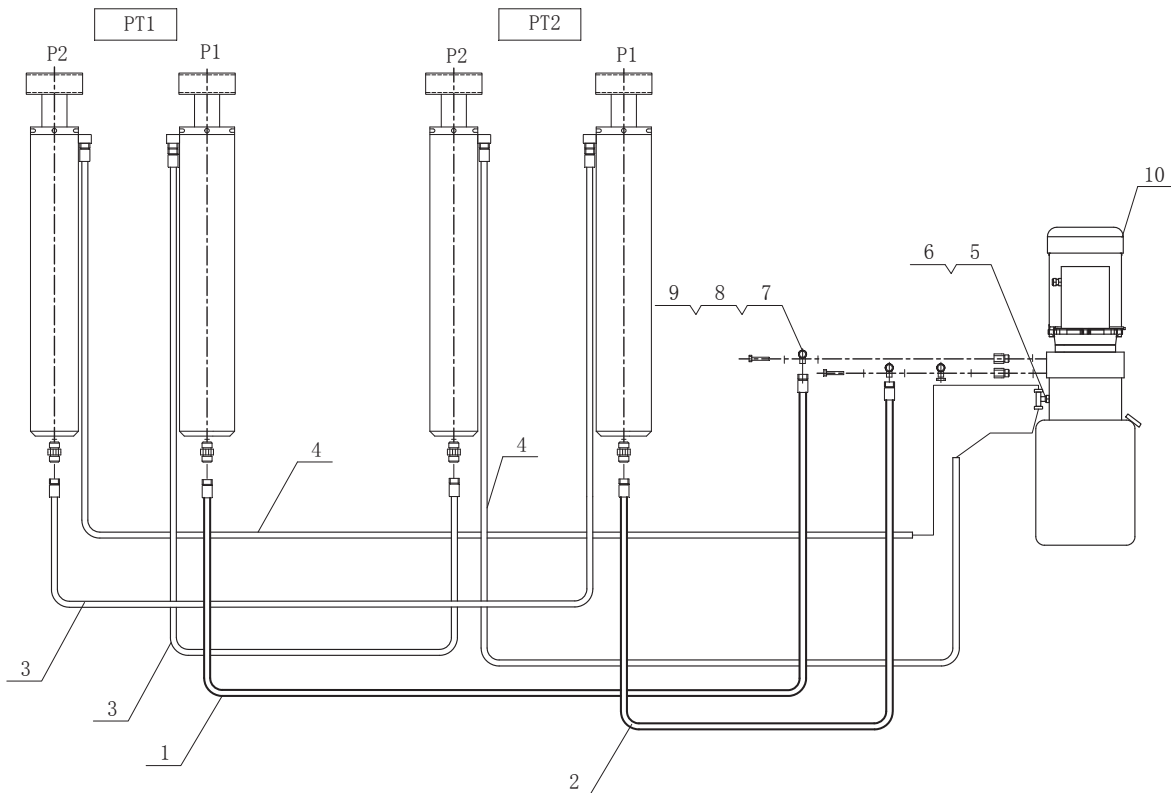

Hydraulic Connection

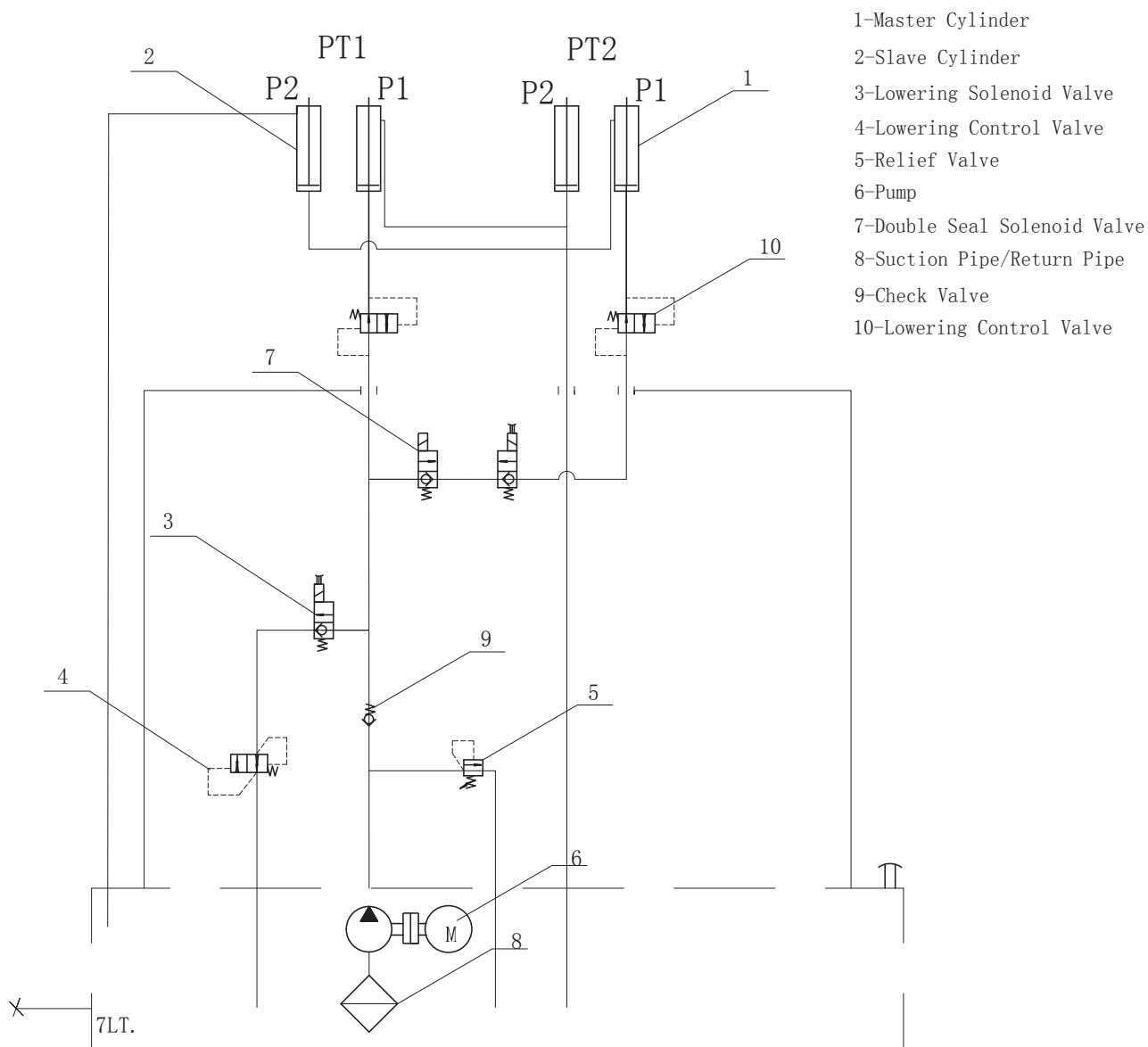

Hydraulic Schematic

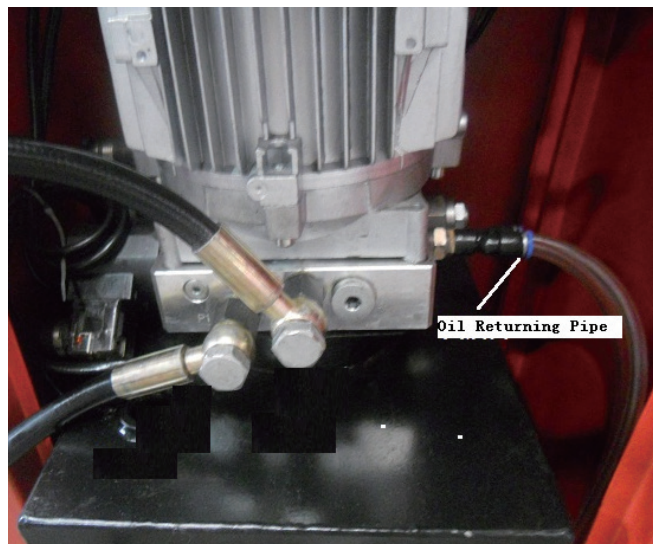



## Electrical installation

- Connect power incoming line according to Electric Schematic, of which three black wires are phase lines, the light blue wire is zero line and the wire in yellow and green is the earth wire. Grounding of the control box should be reliable.
- Check the numbers of the corresponding lines in accordance with the Electric Schematic. Connect the 2-core plug-in unit of a high-position limit switch, and the 2-core plug-in unit of a low-position limit switch with each other. Turn the high-position limit switch and the low-position limit switch on the open mode, so they will not work when refilling and level adjusting.

## Requirements:

- High electrical voltage, only trained professional electricians may work on the electrical system.
- Wiring must be done in a reasonable way.
- It is necessary to fix up a sealed and reliable distribution box.
- Check the data plate of the motor for proper power supply.

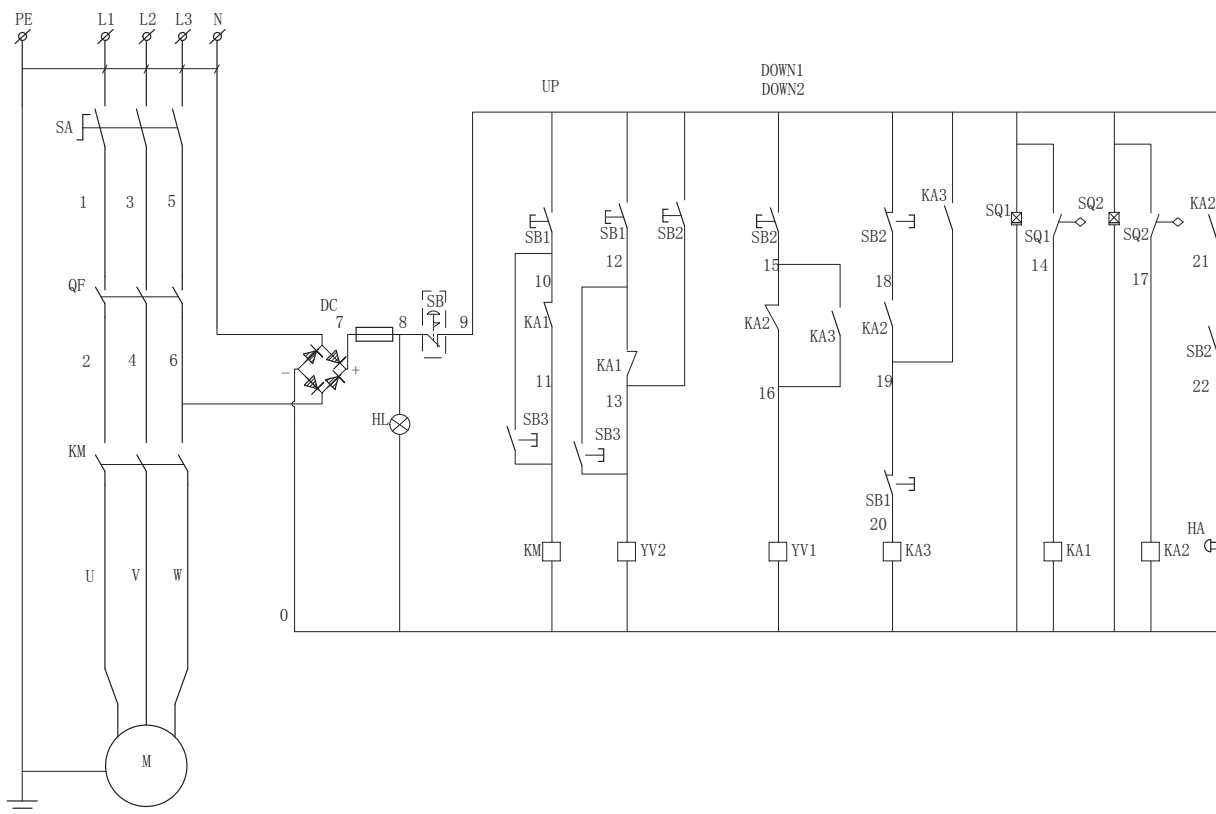

Wire Schematic

- Turn the switch on the cover plate of the control box to the position with “ON”.



- **Levelling two platforms (Before connecting the limit switch wires)**

Bleeding: Keep pushing the raise button, until there is no air bled from the cylinders (See the air return pipe)



- **Levelling two platforms (When operating the lift, two platforms un-levelling)**

Bleeding: Keep pushing the levelling button (Inside of the cabinet), until there is no air bled from the cylinders (See the air return pipe)

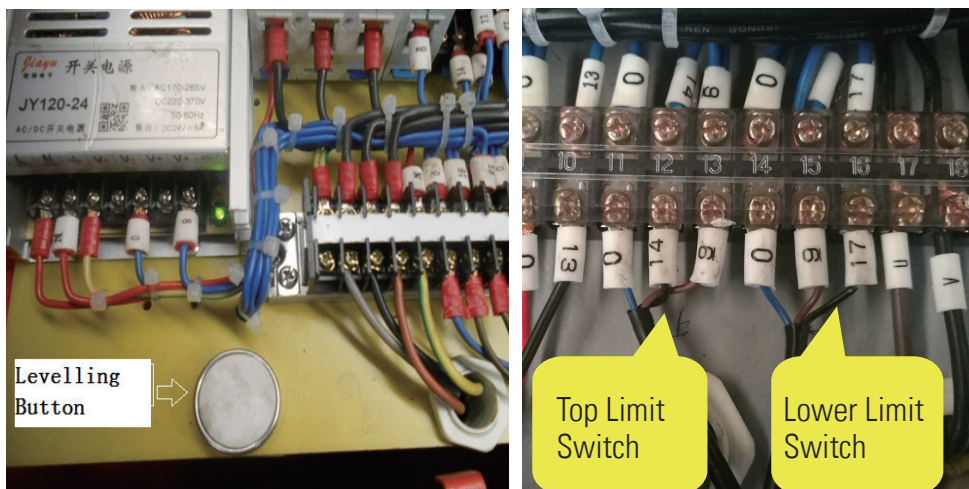

### **III Operation Instructions of Low Profile Scissor Lift**

- Daily inspect your lift. Never operate if it malfunctions or it has broken or damaged parts. Use only qualified lift service personnel and genuine replacement parts to make repairs.
- Thoroughly train all employees in use and care of lift, using manufacture's instructions supplied with the lift.
- Never allow unauthorized or untrained persons to position vehicle or operate lift.
- Prohibit unauthorized persons from being in shop area while lift is in use.
- Do not permit anyone on lift or inside vehicle when it is either being raised or lowered.
- Always keep area around lift free of tools, debris, grease and oil.
- Never overload lift. Capacity of mid raise scissor lift is 3200kg.
- Do not stand in front of the lift or vehicle while it is being positioned in lift bay.
- Before driving vehicle into lift bay, be sure lift is fully lowered.
- Load vehicle on lift carefully. Check for secure contact with vehicle. Raise lift to desire working height.
- Do not go under vehicle if safe locking latches are off-line.
- Do not block open or override self-closing lift controls; they are designed to return to the "off" or neutral position when released.
- Remain clear of lift when raising or lowering vehicle.
- Always lower lift completely and disconnect power source before disconnecting hydraulic lines.
- Avoid excessive rocking of vehicle while on lift.
- Clear area if vehicle is in danger of falling.
- Completely lower lift before removing vehicle from lift area.
- Release safe locking latches before attempting to lower lift.
- If the lift stops automatically when it is in motion, check the photoelectric switch. Don't operate the lift before the photoelectric switch returns to the normal state.
- Normal operating temperature range is 7°C (45°F) to 38°C (100°F).

## **IV Notice for Maintenance and Check of Low Profile Scissor Lift**

### **Daily Maintenance and Check**

- Check safety lock audibly and visually while in operation.
- Check safety latches for free movement and full engagement with rack.
- Check hydraulic connections, and hoses for leakage.
- Check bolts, nuts and screws, and tighten if needed (including those in the hydraulic part).
- Check wiring and switches for damage.
- Make sure that the input power is equipped with a safe grounding line, and check whether grounding of the lift is tight to ensure reliable grounding.
- Check whether the sensor works as required.
- Keep base plate free of dirt, grease or any other corrosive substances.
- Check floor for stress cracks near anchor bolts.
- Any part of the lift should be fastened securely, and no part is allowed to come loose or fall off.

### **Weekly Maintenance and Check**

- Check for any loose anchor bolts. Retighten as necessary. Do not use an impact wrench.
- Check floor for stress cracks near anchor bolts.
- Check hydraulic oil level.
- Check and tighten bolts, nuts and screws (including those in the hydraulic part).

### **Yearly Maintenance and Check**

- Grease the areas where the slide blocks run.
- Change hydraulic oil.

### **Suggestions and Points for Attention**

- When install the fittings to the ports of the power unit, the torque wrench is required, with torque between 24 and 28 NM so as to avoid damage of the valve guide.
- The user is required to use high-quality hydraulic oil in the original packing and change it regularly. Any dirty or recycled hydraulic oil is forbidden.
- It is suggested to lubricate all the movable parts to effectively improve the performance of the lift.

Note: Any article without reference to the model is applicable to the maintenance and check of lifts of all the models.

## V Troubleshooting of Low Profile Scissor Lift

Trouble	Cause	Remedy
The electric motor does not run	<ol style="list-style-type: none"> <li>1. The fuses are blown or the over-current protective device is faulty</li> <li>2. The voltage to motor is wrong</li> <li>3. The electrical wires are disconnected.</li> <li>4. The motor contactor is faulty.</li> <li>5. Blown fuse on 24V power supply.</li> <li>6. The transformer is faulty.</li> <li>7. The motor thermic switch is activated from overheating.</li> </ol>	<ol style="list-style-type: none"> <li>1. Replace the blown fuses or reset the over-current protective device.</li> <li>2. Supply correct voltage to motor.</li> <li>3. Repair and insulate all connections.</li> <li>4. Check the contactor coil operation and make sure it is activated when supplied with 24V.</li> <li>5. Check the fuse on the transformer and replace it if necessary.</li> <li>6. Check the output voltage of the transformer (24V).</li> <li>7. Wait for 10 minutes and try starting again; then, using a tester to make sure contact is closed again.</li> </ol>
The electric motor runs but will not raise lift.	<ol style="list-style-type: none"> <li>1. Motor runs in reverse rotation.</li> <li>2. Load too heavy.</li> <li>3. Low fluid level.</li> <li>4. The master hydraulic circuit breaks.</li> <li>5. The oil filter is clogged.</li> <li>6. Faulty hydraulic pump.</li> <li>7. Faulty relief valve.</li> <li>8. The disc of the lowering solenoid valve is dirty.</li> <li>9. The emergency lowering throttle valve is open.</li> </ol>	<ol style="list-style-type: none"> <li>1. Switch the phase and make sure motor runs in the direction indicated by the arrow.</li> <li>2. Check vehicle capacity.</li> <li>3. Fill tank with hydraulic oil.</li> <li>4. Check and retighten.</li> <li>5. Check and clean.</li> <li>6. Repair or replace the hydraulic pump.</li> <li>7. Adjust and replace the relief valve.</li> <li>8. Check the solenoid valve and clean the disc.</li> <li>9. Check and tighten screw.</li> </ol>
The motor has sounds, but can't run.	Default phase occurs to the three-phase power supply.	Immediately stop to run the motor, and check whether default phase occurs to the main circuit.
The lift rises too slowly.	The seal of the hydraulic pump is damaged, resulting in oil leakage.	Repair or replace the hydraulic pump.

<b>Trouble</b>	<b>Cause</b>	<b>Remedy</b>
The lift vibrates while working.	<ol style="list-style-type: none"> <li>1. There is air in the hydraulic circuit.</li> <li>2. The oil filter is dirty.</li> <li>3. The gas leaks in the upper part of the suction pipe of the hydraulic pump.</li> </ol>	<ol style="list-style-type: none"> <li>1. Bleed repeatedly the hydraulic circuit according to the Operation Manual.</li> <li>2. Check and Clean the oil filter.</li> <li>3. Check and replace it.</li> </ol>
The down button is pressed but the lift does not lower.	<ol style="list-style-type: none"> <li>1. Make sure there are no obstacles blocking the lowering phase.</li> <li>2. There is the poor contact inside the button.</li> <li>3. The input voltage is abnormal.</li> <li>4. Blown fuse on 24V power supply.</li> <li>5. Faulty transformer.</li> <li>6. The lowering Solenoid valve coil is faulty or not supplied with current.</li> <li>7. Damaged or faulty lowering solenoid valve.</li> <li>8. The air pressure is insufficient to release the safety locks.</li> </ol>	<ol style="list-style-type: none"> <li>1. Remove the obstacles blocking the lowering phase.</li> <li>2. Check and replace the button.</li> <li>3. Return the input voltage to normal.</li> <li>4. Check and replace the fuse after eliminating the cause of the short circuit.</li> <li>5. Check the output voltage of the transformer (24V).</li> <li>6. Check to see if valve coil is getting current.</li> <li>7. Unscrew the valve on the hydraulic block and make sure it moving freely when supplied with 24V solenoid.</li> <li>8. Adjust the air pressure in the compressor.</li> </ol>
The lift isn't raising synchronous.	<ol style="list-style-type: none"> <li>1. The refilling valve is open.</li> <li>2. Leakage occurs in the hydraulic circuit.</li> </ol>	<ol style="list-style-type: none"> <li>1. Bleed and readjust the balance, and fasten the refilling valve.</li> <li>2. Eliminate the leakage in the hydraulic circuit.</li> </ol>

# VI Parts Break

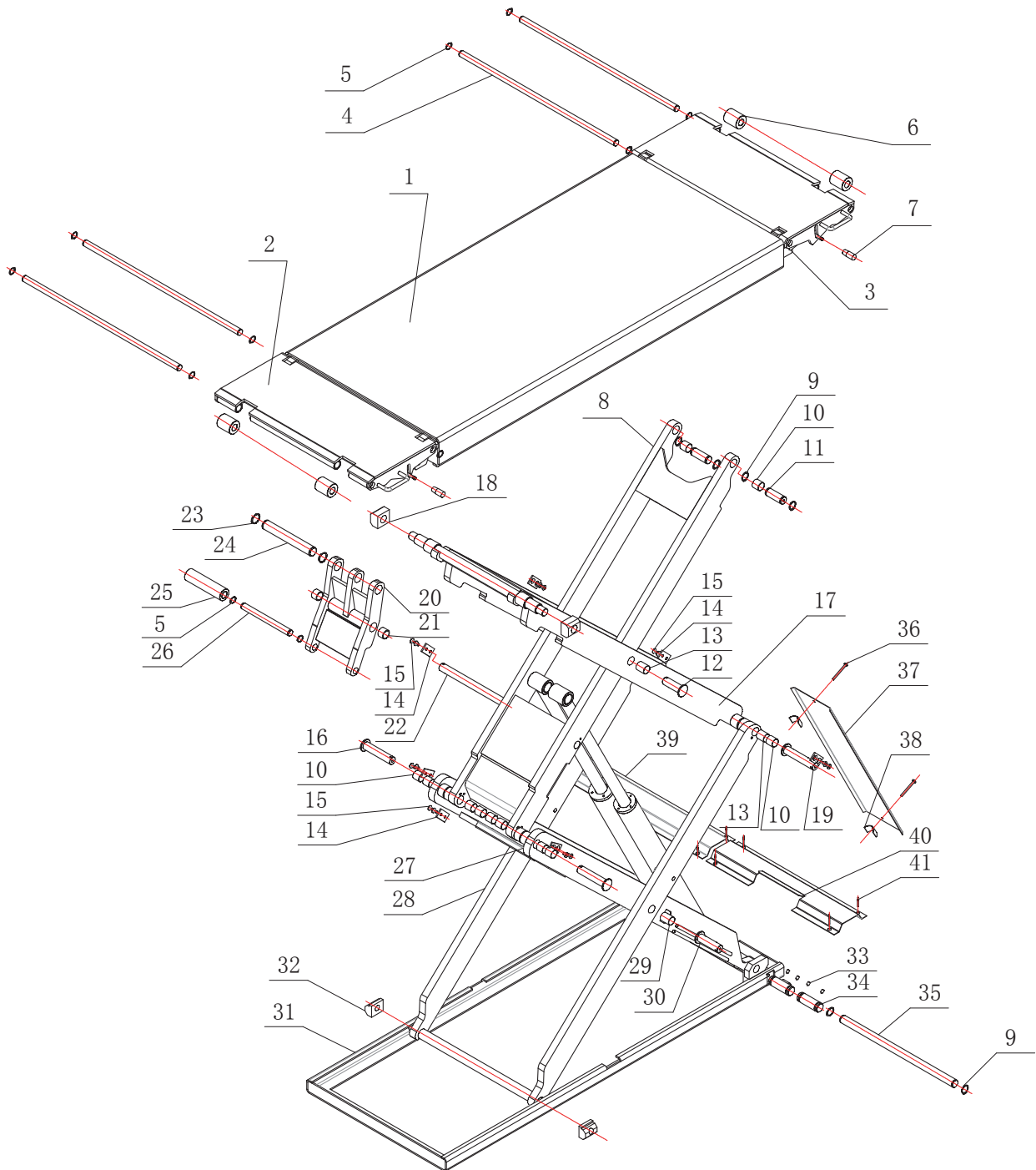

<b>Item Number</b>	<b>Part Number</b>	<b>Description</b>	<b>QTY</b>
1	RT1001C	Platform	2
2	RT1002C	Ramp	4
3	RT1003C	Ramp Support	4
4	RT1004C	Shaft	4
5	RT1005C	Circlip 20	8
6	RT1006C	Roller	8
7	RT1007C	Handle Bar	4
8	RT1008C	Inner Leg (UP)	2
9	RT1009C	Circlip 25	4
10	RT1010C	Bearing	16
11	RT1011C	Pin	8
12	RT1012C	Shaft	4
13	RT1013C	Bearing	4
14	RT1014C	Lock plate	8
15	RT1015C	Bolt M8x16	8
16	RT1016C	Pin	4
17	RT1017C	Outer Leg (UP)	2
18	RT1018C	Slider Block	8
19	RT1019C	Pin	4
20	RT1020C	Kicker Weldment	2
21	RT1021C	Bearing	4
22	RT1022C	Pin	4
23	RT1023C	Circlip 30	8
24	RT1024C	Pin	2
25	RT1025C	Kicker Roller	4
26	RT1026C	Kicker Roller Pin	2
27	RT1027C	Inner Leg (Down)	2
28	RT1028C	Outer Leg (Down)	2
29	RT1029C	Bearing	12
30	RT1030C	Shaft	2
31	RT1031C	Base Frame Weldment	2
32	RT1032C	Slider Block	4
33	RT1033C	Bolt	8
34	RT1034C	Cylinder Fixed Pin	4
35	RT1035C	Shaft	4
36	RT1036C	Bolt M6x70	4
37	RT1037C	Cylinder Cover	2
38	RT1038C	Plate	4
39	RT1039C	Hose Cover	1
40	RT1040C	Hose Cover	2
41	RT1041C	Nylon Anchor M6x40	12



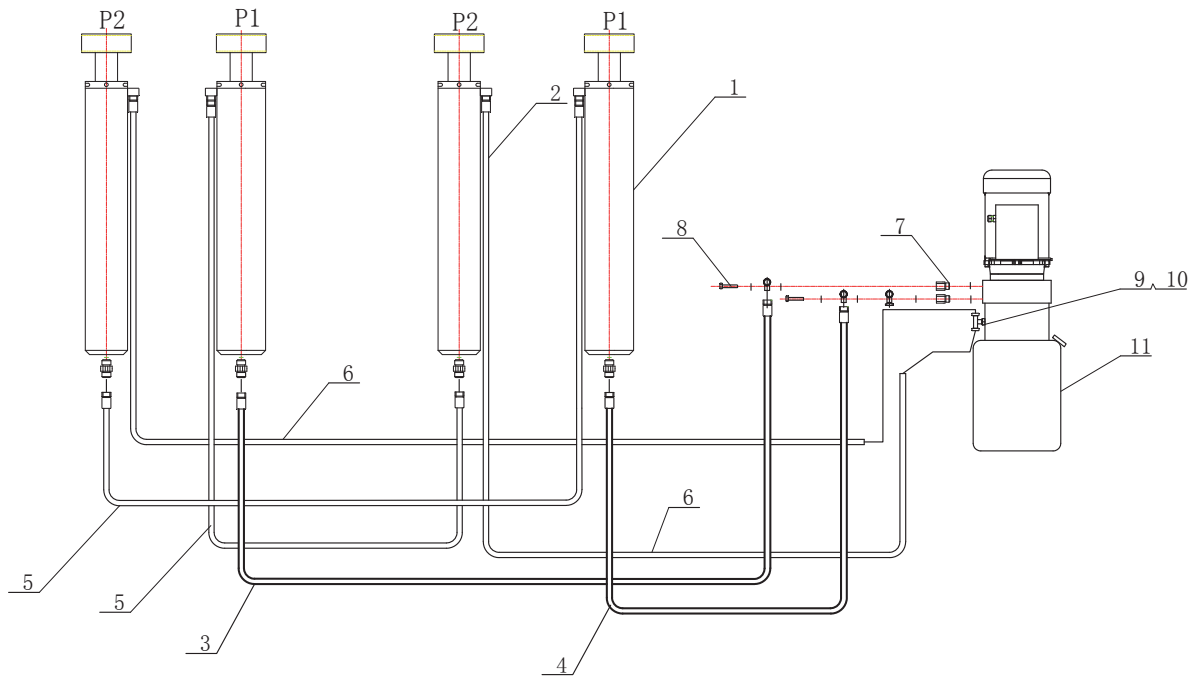

Item Number	Part Number	Description	QTY
1	RT2001C	Master Cylinder	2
2	RT3001C	Slave Cylinder	2
3	RT4001C	Hydraulic Hose L=4200mm	1
4	RT4002C	Hydraulic Hose L=2900mm	1
5	RT4003C	Hydraulic Hose L=2600mm	2
6	RT4004C	Return Pipe	2
7	RT4005C	Fitting	2
8	RT4006C	Bolt	2
9	RT4007C	Air Fitting	1
10	RT4008C	Y version Air Fitting	1
11	RT4009C	PU	1

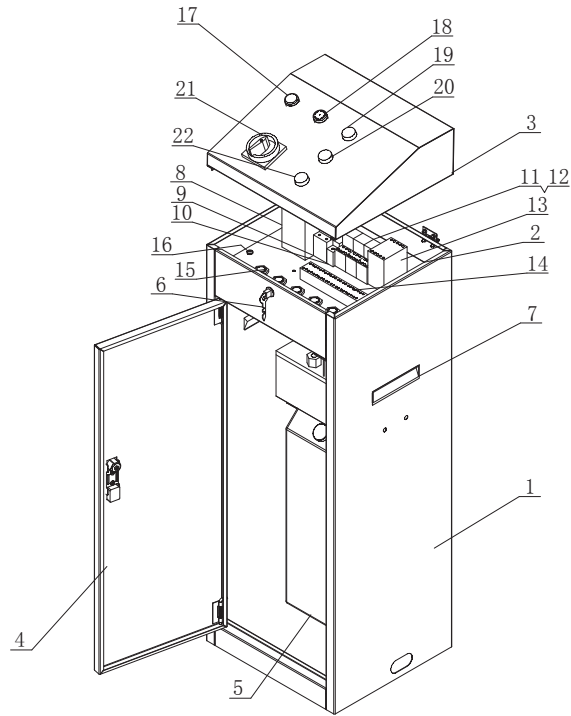

Item Number	Part Number	Description	QTY
1	RT5001C	Cabinet	1
2	RT5002C	Supporting Plate	1
3	RT5003C	Cover	1
4	RT5004C	Door	1
5	RT5005C	Power Unit 380V/50hz	1
6	RT5006C	Lock	1
7	RT5007C	ABS Handle	1
8	RT5008C	Power Switch	1
9	RT5009C	Breaker	1
10	RT5010C	Fuse	1
11	RT5011C	Relay 24V	1
12	RT5012C	Timing Relay	1
13	RT5013C	Contactor	1
14	RT5014C	Wiring Board	1
15	RT5015C	Tightener PG13.5	1
16	RT5016C	Screw M6x10	1
17	RT5017C	Power Light DC24V	1
18	RT5018C	Buzz DC24V	1
19	RT5019C	Lifting Button	1
20	RT5020C	Lowering Button	1
21	RT5021C	Power Switch	1
22	RT5022C	Emergency Switch	1

**Vehicle Service Group<sup>SM</sup>  
Rotary Lift Consolidated  
(Haimen) Co., Ltd**  
No.1388,East Xiushan Road,  
Haimen,Jiangsu Provice,China  
[www.vsgdover.com](http://www.vsgdover.com)



© **Vehicle Service Group<sup>SM</sup>**  
All Rights Reserved. Unless otherwise  
indicated, **Vehicle Service Group<sup>SM</sup>**  
and all other trademarks are property  
of Dover Corporation and its affiliates.